

JP18

High sensitivity GPS receiver

- GPS module based on SiRFstarIII - GSC3LTf chip
- High sensitivity for indoor fixes
- Extremely fast TTFF at low signal levels
- 200.000+ effective correlators
- Integrated TCXO
- On chip 4 Mb FLASH + 4 Mb ROM
- ARM7 baseband CPU
- GSW3 software support
- Starter-kit including evaluation and configuration tool

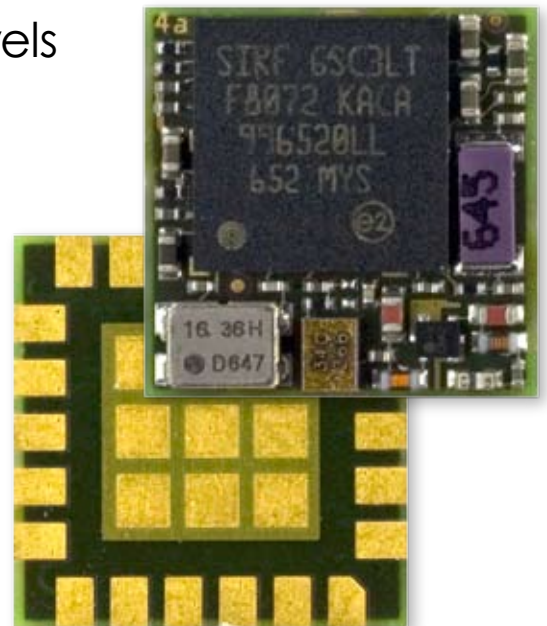

The FALCOM JP18

is a new of highly integrated, low-power GPS product – based on a 0.13 micron CMOS process of the SiRFstarIII - GSC3f – architecture. It is a single-board solution with increased to 20 parallel channels. The JP18 unit for the first time combines a complete AGPS digital baseband processor, RF front end, 4 Mb ROM and 4 megabits of flash memory in a small size, providing manufacturers of cell phones, PDAs and other portable and wireless devices with a drop-in AGPS solution they can use to deliver real-time location and navigation capabilities

in a simpler, smaller design with extended battery life. This unit will deliver exceptional sensitivity, low power consumption and extremely fast time to first fix (TTFF) in a compact, (11 x 11 mm, 22 pin) package. The digital section of the GPS receiver includes a powerful SiRFstarIII core GPS signal processor that handles all the time critical and low latency acquisition, tracking and reacquisition tasks autonomously, and a 50-MHz ARM7TDMI processor designed to run many OEM user applications.

JP18 Block diagram

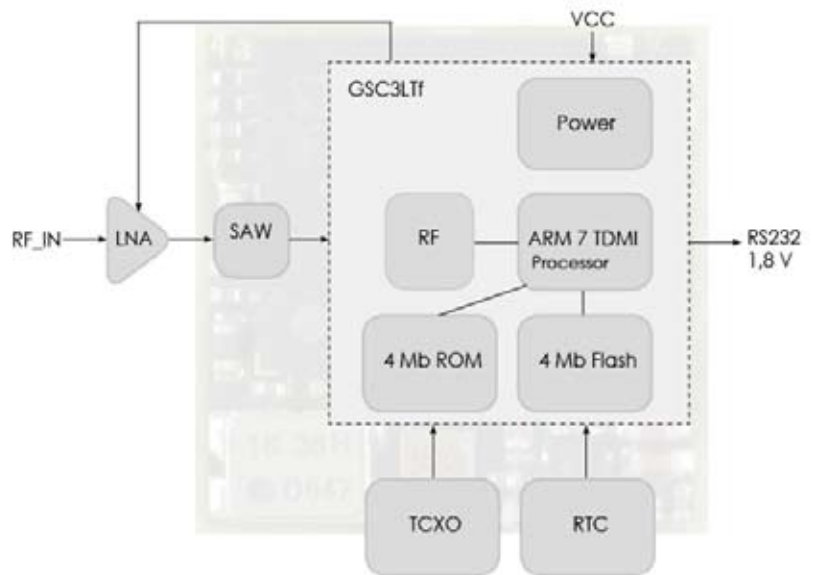
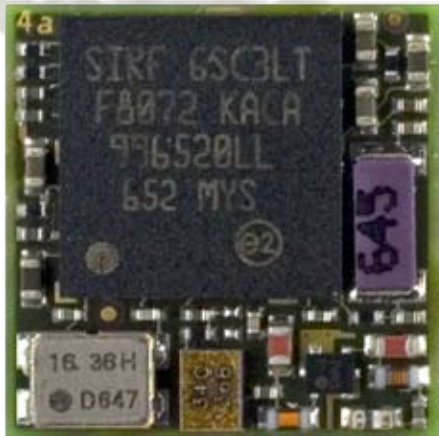

Applications

Compared to the JP13-S, the JP18 is more optimized for location applications requiring high performance in a very smaller form factor – 11 x 11 mm, ideal for devices with limited onboard processing power.

The JP18 concept builds perfect basis for the design of high-sensitive, low-power, compact and cost efficient state-of-the-art GPS enabled system solutions for target platforms such as mobile phones, automotive systems, portable computing devices, and embedded consumer devices. The FALCOM JP18 is also designed to be entire product such as AVL tracking unit or hand-held GPS.

Technical specification

Time to first position (TTFF)	JP18
Hot start	< 1 sec average (23 dBHz sensitivity)
Warm start	< 35 sec average (28 dBHz sensitivity)
Cold start	< 35 sec average (16 dBHz sensitivity)
Sensitivity	
Autonomous acquisition	-142 dBm
GSM / UMTS coarse time aided	-155 dBm
CDMA precise time aided	-155 dBm
Tracking	-159 dBm
Position accuracy	
Autonomous	< 2,5 m
SBAS	< 2,0 m
Receiver	
Tracking	L1, CA code
Channels	12 - 20
Max. update rate	1 Hz
max. altitude / velocity	< 60.000 ft / < 1.000 knots
Protocol support	NMEA, SiRF binary
GPS-Datum	
	WGS-84
Processing core	
Processor type	ARM7/TDMI
Core voltage	1,2 V
FLASH	4 Mb
ROM	4 Mb
Electrical characteristics	
Power supply	3,3 V - 5,5 V
Power consumption	27 mA continuous mode
	9 mA trickle power (1 sec)
Physical characteristics	
Size	11 x 11 mm

Note: Specifications and information given in this document are subject to change by FALCOM without notice.
For latest product information see www.falcom.de